



JISSE

ISSN: 2636-4425

Journal of International Society for Science and Engineering

Vol. 2, No. 1, 16-21 (2020)

JISSE

E-ISSN:2682-3438

Implementation of Smart Bulb Lighting System Using Android

Manu Ahuja*¹ and Marwa M. Ibrahim²

¹Ex Assistant Professor, Electrical and Electronics Engineering Department, HMR Institute of Technology and Management, Delhi, India

²Researcher, Mechanical Engineering Department, Engineering Research Division, National Research Centre (NRC) 12622, Egypt

ARTICLE INFO

Article history:

Received:19-01-2020

Accepted:12-02-2020

Online:14-02-2020

Keywords:

Lighting system;

PWM;

Smart bulb;

RGB; Android;

LED

ABSTRACT

Colors and light intensity have a great impact on daily life work and helps boost work efficiency. The color is used to change once mood, treat various psychological illness, and increase brain hormonal activities up to a certain extent. The light plays a significant role in making the surrounding cooler than usual. These colors affect the eyes and it is very important to keep the surrounding light color and brightness adjusted to a certain limit. Color with low brightness increases hormonal activity at night and sleep rate. Smart bulb uses three primary color Red, Green and Blue (RGB) for making different colors. The Smart Bulb is designed to change color and vary the intensity of the room or the workplace enhancing the working efficiency. Smart Bulb pairs with android application designed to provide an interface to control the bulb. The Smart Bulb utilizes inbuilt temperature and humidity sensors to collect environmental data and changes the intensity of the bulb accordingly. It also has special features like music control RGB pattern which varies its light according to the musical rhythm, bass, and treble. The android application in this paper is used for many applications for example to control various features like intensity and color of smart bulb, display temperature and humidity data on smart phone, switches on and off the bulb, gives notification alert by changing its color.

1. INTRODUCTION

The environment light intensity and color can affect human activity such as working efficiency, mood, metabolism, mindset, and certain brain hormonal activities. There are many treatments that are carried out using the light that help change the brain activity to certain extent. The work efficiency of humans gets influenced by surrounding light. A good light intensity and color can help build a good working place. The light color helps to manage stress, sadness, anger, and depression. The light color also helps to increase the feeling of happiness, joy and improve the state of mind.

For a long time, there were energy-efficient alternatives to incandescent light bulbs available. We have not taken hold in a significant way for one reason or another-but that is about to change. Market conditions have converged in such a way that LED bulbs are primed for widespread consumer adoption as of 2017. Prices are down, profits are up, and customer satisfaction is improved by an objective certification process against

stringent performance norms.

Smart Bulb is a bulb designed to change the surrounding light intensity and color according to need. It includes different options that can be used to create different effects. All these features help provide great comfort to the eyes by keeping the sharpness or brightness falling on the eyes to minimum. The color affects the temperature by making the surrounding cooler or warmer than usual it feels to be. Smart Bulb consists of a sensor that is used to collect the data regarding surrounding temperature and humidity. This data is then changed to values that are conducive for surrounding color to boost the mood of the person. Hence, the work efficiency is increased; sleep rate and hormonal activities are normalized.

Smart Bulb provides a simpler solution for making the surrounding light intensity and color near to optimum so that the user can get a good surrounding environment.

Good surrounding means a good peace of mind and this can increase the overall efficiency in daily life. It provides a relaxing environment where one can rest keeping the surrounding light under their control.

* Manu Ahuja, Department of Electrical & Electronics Engineering, Institute of Technology and Management, Delhi, India, +91 9711754344, manuahuja9@gmail.com

2. PREVIOUS WORK

Many previous researchers work on effect of the color on human, human brain, mood, and work have been conducted. Also, the color change on music beat and rhythm. F. Nouvel *et al.*, presented a paper which gives the analyses of any input signal to control both the color and intensity of lamps using Light Emitting Diode (LED) [1]. It wirelessly receives the input signal which can be an audio signal and converts it to a value that is fed to the RGB LED's and a specific color and intensity is produced. In another research X. Qu, et al. proposed a successful method to effectively control the color of the systems that involve light sensor [2]. They presented an effective way of controlling the color and stabilizing it that involves light sensor by eliminating the need of expensive feedback system. S. Mahadeokar and M. Sardeshmukh presented a paper in which they used the PWM (Pulse Width Modulation) technology for the dimming action of LED's due to which the junction temperature of LED decreases and the LED module life increases [3]. Also, they showed in this way a huge energy could be saved. Chun Wei Lin et al. proposed a dimming technique for LED through controlling the current regulation and it provides an 8-bit resolution for intensity adjustment [4]. For this PWM and multilevel generator are used. In a paper by G. Curcio et al. various effects of color on sleep, sleepiness, mood, and vigor were indicated [5]. The light condition consisted in a 4000 K LED light showed positive result on night sleep latency and other experimental results at different LED light conditions. In another paper de Melo and Gratch proposed a work on virtual human in which they discussed various results of the expression of emotion on different color exposure [6].

Recently, smart lighting has received a great deal of global attention as it is an advancement from human-centric lighting with light-emitting diodes (LEDs) [7],[8] and/or organic light-emitting diodes (OLEDs) for dual use, illumination and communication [9]. This technology aims to fuse drivers with sensing, control algorithms, and wireless communications to deploy scalable lighting systems that can work autonomously within the environment of the Internet of Things (IoT). A common definition for smart lighting is a lighting system that includes energy-efficient LED drivers, miniaturized digital lighting sensors, advanced control algorithms, and structured interfaces for communication and interaction in a lighting network.

Additional features beyond traditional lighting purposes are among the most advanced lighting systems. These technologies are linked to spectrally tunable functionality, optical communications and expanded control capabilities that open a new paradigm associated with the possibility of remote control of the device from the Internet and mimic any possible light spectrum in real time. Solid State Lighting (SSL) systems are typically effective solutions for home and industrial applications. The luminous efficacy of LEDs in these systems is growing each year, while their price is steadily falling. In addition, the luminous efficacy will increase every decade according to Haitz's law predictions [10] and the cost per

lumen will continue to decrease in the future. This prediction is largely fulfilled as a result of developments in material science predicting that the amount of light emitted per LED is that each year. Furthermore, since smart LED-based lighting systems involve non-polluting materials, several studies show a positive Life Cycle Analysis (LCA) [11] which makes SSL technology very attractive in current and future smart lights.

Smart lighting systems primarily provide digital sensors, drivers for actuators, and interfaces for communication. Such lighting systems are designed using advanced control algorithms and for remote operation, they can be grouped into lighting networks. Some of the most common approaches are designed to modify the light or color spectrum. It is also possible to monitor the lighting level in a room when an external event occurs, e.g. when a consumer has been identified by an occupancy sensor or when an event occurs such as detecting vehicles or people on a road.

The first two stages of the LED driver are connected to the power supply that involves the power factor correction and the DC-DC conversion element while the third stage concerns current control based on linear constant-current LED drivers or constant-current LED drivers switching. Boost, Buck, Buck-Boost regulators or SEPIC are common architectures to turn LED drivers at constant current [12]. Different types of LED drivers can achieve high conversion efficiencies across a wide range of voltages between 85 per cent-95 per cent. When using pulse-width modulation (PWM) [13], LED drivers are susceptible to excess noise generation induced by intermittent high frequency switching. LED drivers also include dynamic dimming capabilities to prevent distracting flicker while increasing the overall device efficiency to avoid noticeable and non-visible low frequency flickering.

Smart lighting solutions incorporate various devices, systems, and types of networks. Devices are primarily luminaries with sensors, actuators, and advanced algorithms. A couple of advanced algorithms allow a final action to be decided for monitoring daylight levels, light spectrum, or user occupation. The algorithms run within computers, or the algorithm can run directly in the cloud stored as a web service to send command messages to perform the different control actions to relieve the device's workload. Several smart lighting algorithms are related to advanced operations such as real-time tuning of the color reproduction. Owing to advances in smart lighting systems that can influence human circadian rhythms to improve user mood and concentration, this feature is being impressive on the market.

3. LIGHT BULB MARKET SHARE

The first LED bulbs entering the market around 2007 provided very low levels of light and were not suitable replacements for conventional bulbs. Many early designs were otherworldly; many of the early bulbs used LEDs on the white light spectrum's blue (cool) end, and they could not balance the light output or disperse the light as standard bulbs might. Additionally, early-to-market designs did not manage the small amount of heat generated by the LEDs themselves, thus prematurely burning out. Today, LED bulbs look and act just

like old, common incandescent bulbs: instant on, quality light all around. Most are designed to dim; some get warmer in color as they dim; and some are designed to fit the appearance of trendy vintage-style bulbs. Efficiency keeps on rising. In 2012 the first real 60W LED replacement used about 13 W. Today, the average LED 60W replacement approved ENERGY STAR uses 9W, while some use as little as 7W, like the vintage-style one. Dimming experience is the last big hurdle for consumer satisfaction, and efforts to solve this are reaching a significant turning point. Consumers will have the tool readily available this year to easily identify compatible LED bulbs and dimmers. The light bulb technology is presented in Figure 1, [14].



Figure 2: Common Bulb Technologies with Annual Electricity Cost, [15]

4. SYSTEM ARCHITECTURE

In this section, a detailed overview of the proposed work with block diagram is provided.

4.1 Overview

The goal of the proposed work is to design Smart Bulb that can be controlled using android application. The Smart Bulb is a way different from normal LED bulbs as it produces different color depending on the user command. The smart bulb contains three primary color LED i.e. Red, Green and Blue that are used to change color and intensity of the bulb and set color according to the mood. It also contains inbuilt sensor that enables defining room temperature and humidity. The block diagram of the Smart Bulb is presented in the Figure 3.

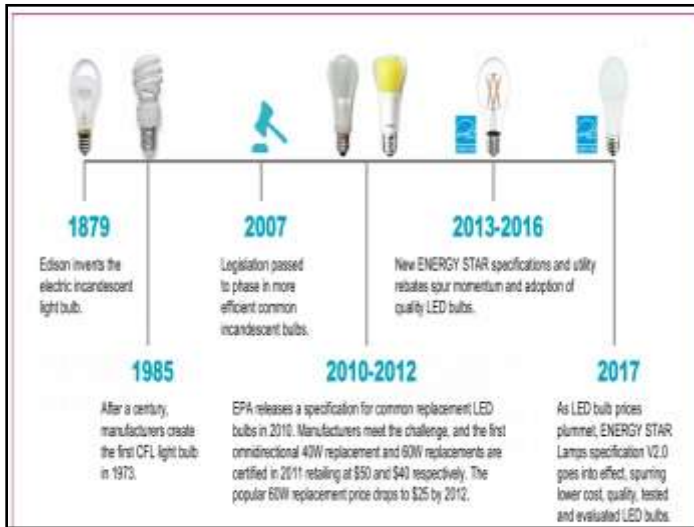

Figure 1: Light Bulb Technology Milestones, [14]

Market conditions have converged in such a way that LED bulbs are primed for widespread consumer adoption as of 2017. Prices are down, profits are up, and customer satisfaction is improved by an objective certification process against stringent performance norms. For more than a century, conventional incandescent light bulbs, the ubiquitous 100, 75, 60 and 40W bulbs, have served American basic lighting needs, but 90 per cent of the energy used is wasted heat and only 10 per cent is used to provide electricity, effectively lighting homes with small heaters. On the other hand, LED bulbs are about 90 percent effective, and replacements for the most commonly used light bulbs, the 40 & 60W incandescent bulbs, can now be bought for \$2 or less across the USA. The American home on average has around 50 sockets. About 60% of them still contain an inefficient light bulb. High-quality, two-dollar LED bulbs will fill those sockets and save Americans over \$6 billion a year to light up their homes. The diagram in Figure 2 shows that annual energy costs vary considerably by technology, [15].

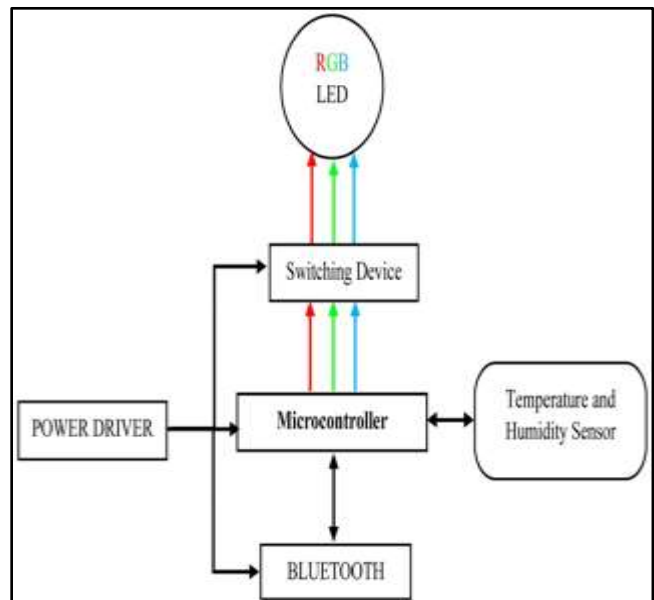

Figure 3: Block Diagram of Smart Bulb.

Smart Bulb is simple to build and uses readily available and inexpensive components. The components consist of a CFL spiral bulb, an AC-rated halogen bulb like the CFL, a Thermistor, and the control circuits. The halogen bulb in mounted in the center of the CFL spiral ensures that all the

tube is reached evenly by heat. The shadows caused by the CFL partially blocking the halogen light are one drawback to this method. This can be changed by installing a shadow softener diffuser. To measure temperature, the Thermistor is placed under the halogen bulb. This position shields it from direct heat and gives the ambient temperature around the tubes a better estimate. The last part is the circuit which controls the logic of switching. To make the control circuit design easier, it is operated by a DC voltage. To power the control circuit, this requires a small AC to DC converter. Figure 4 is a block diagram of how to connect the circuits, and how to move the different bulbs.

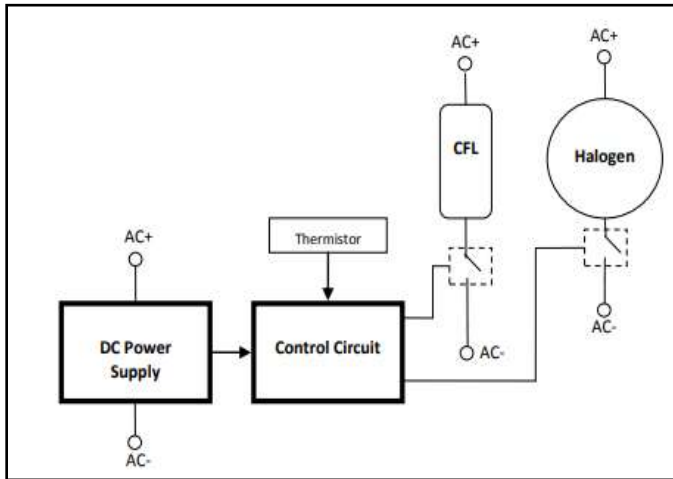

Figure 4: Basic Circuit Block Diagram of Smart Bulb

4.2. Smart Bulb inbuilt sensor

The Smart Bulb has inbuilt temperature and humidity sensor. The primary function of these sensors is to get the surrounding temperature and humidity that can be used to set the intensity and color of the Smart Bulb. The data of these sensors can be seen directly on the android application.

4.3. Microcontroller

The Smart Bulb uses ATMEGA328 microcontroller which is the brain. It receives the command over Bluetooth and do produce various output. It uses the switching device to switch RGB LED's with the help of Pulse Width Modulation (PWM) technique. Using this power delivered to each LED can be controlled and ultimately the color and intensity of each LED. The PWM value can be varied from 0 to 255 i.e. the duty cycle varies from 0% to 100%. So, by varying these three primary colors we can obtain 255x255x255 different colors combination.

The microcontroller is connected to the sensor of temperature and humidity from where it receives the ambient temperature, humidity, and heat index and the data is sent to the connected android smart device via Bluetooth. The beginning cycle of the Smart Bulb bulbs is shown in Figure 5.

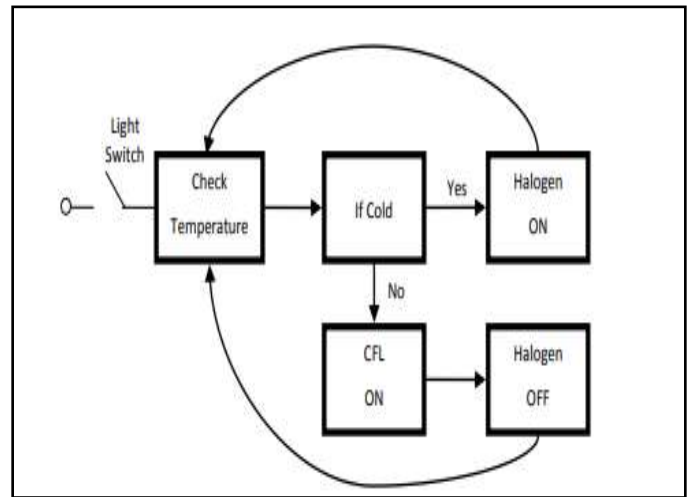

Figure 5: Basic Logic for Smart Bulb

4.4. Bluetooth 4.0

The Smart Bulb system uses Bluetooth 4.0 which is a low energy device that increases the overall efficiency. The device makes use of Advanced Audio Distribution Profile to receive the music and convert it to PWM signal for RGB LED's to produce different color and intensity according to musical rhythms, beat, bass and treble.

4.5. Switching Device

The switching device is isolation and a bridge between LED which work at 12V and microcontroller working at 5V. This switching device ensures the safety of microcontroller and is can work at very high frequency due to which the power delivered to RGB can be controlled. The switching depends on the duty cycle of the PWM wave fed. The switching device used is solid-state to reduce the power wastage and increase the working life.

4.6. Power Driver

Power Driver is used to convert the alternating current to different voltage level direct current. There are three voltage levels +12 volts, +5 volts, and +3.3 volts that are used. The power driver ensures and maintains the voltage level during the load and provides the desired current to different sections. The +5 volts are used to drive the microcontroller, +3.3 volts is used to drive the Bluetooth module, and +12 volts is used to drive the RGB LED's.

4.7. Android application

Android application is designed to connect Smart phone with Smart bulb that provides a user-friendly interface for controlling intensity, color, get the temperature and humidity, and generate different patterns, notification alert, and many other options.

5. SYSTEM IMPLEMENTATION

Smart Bulb is implemented as a smart device that can be used in daily life for making the surrounding light according to need. The Smart Bulb is connected to the android application designed for it. This android application provides a user-friendly interface. One can select from various option available on the app. This can be used to control the Smart Bulb. Smart Bulb uses low energy Bluetooth module that reduces the overall power usage during the standby. The Bluetooth module is used to wirelessly send and receive the data. The Smart Bulbs has an embedded temperature and humidity sensor that is used to get the room or workplace temperature and humidity. This data is being used to determine the intensity and color that can be produces to make the color of light and brightness to optimum. It can be switched between auto change and manual option according to need.

The Smart Bulbs are connected with android application and the color of the RGB LED's is changed according to the value received. This value has two parts, one is the address which is decoded, and the second part is the RGB value which is de coded and the corresponding PWM signal is generated fed to the switching device where the fast switching action enables transfer of required power.

The musical signal is analyzed in matrix and then the required PWM signal for RGB is generated. This value of Red mainly depends on the Bass, Green and Blue color depends on the mid wave signal and the treble of the music.

The algorithm used in Smart Bulbs proposed design is:

- Smart Bulb powers up and waits for pair request.
- After pairing it waits for the data.
- On receiving the 'ON' command the bulb switches on and produces the last color state from the memory.
- When it receives the command for sending the temperature and humidity value.
- It fetches the data from the sensor connected.
- Then it transfers the data using the Bluetooth.
- Waits for next command.
- On receiving the command, it runs the corresponding function and produces the effect needed.

Figure 6 shows the android application activity flow chart that describes the activity flow and the basic working model of android application. There are various operation modes of the Smart Bulb. The user can select from various available option in android application as under:

- Custom light mode: can be used to set custom value of light.
- Mood light: User can change the color randomly or manually saved color sequence.
- Changing light: This is the random mode in which the color changes randomly, after specified time delay.
- Dim mode: In this mode, color changes randomly but with dimming or fading action.

- Night light: The user can select the night light and use the Smart Bulb as night bulb.
- Music mode: User can play songs on smart phone and get the light effect according to the beat, rhythm, bass and treble of the music.
- Temperature mode: In this mode, the color of the light and brightness will change according to the temperature rise and fall and surrounding.
- Selective mode: User can select different colors and change the color according to the choice.
- Alarm: The user can set the alarm that will flash different light during alarm time.
- Notification alert: Set color that will flash when there is notification by other applications.
- Shake up: In this user can shake the phone and change the color of the bulb.

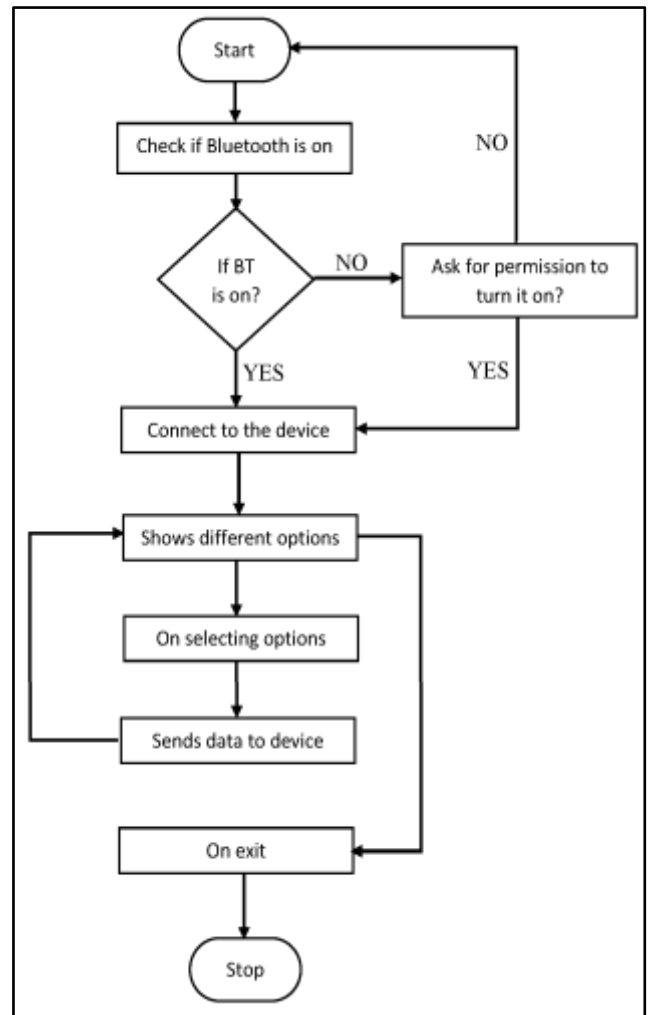

Figure 6: Android Application Activity Flow Chart

Smart lighting is expected to have huge impact during the upcoming years, due to the accelerated deployment of LED drivers, sensors, and connected LED platforms. Behind this tendency, different vendors are in a race to connect smart LED luminaries on the same infrastructure of the IoT. This trend is initially being spread across home and professional applications in indoor and outdoor environments. Lighting appliances and the IoT ecosystem converge in several areas: health and wellness with circadian LED systems, lighting systems with advanced sensing, optical communications, and location services. Moreover, such lighting systems require the use of wired and wireless connectivity to be connected to the Internet. However, as the jungle of wireless standards and protocols is evolving, manufacturers need to adapt their products to lighting market tendencies especially when it is combined with the IoT ecosystem and advanced lighting control systems.

6. CONCLUSION

Smart lighting is an underlying concept that links three main aspects: solid state lighting (SSL) technologies, advanced control and global standards-compliant communication interfaces. However, this conceptualization is constantly evolving to meet the guidelines of the next generation of devices that function in the ecosystem of the Internet of Things (IoT). Current intelligent lighting systems are based on technology for light emitting diode (LED) and include specialized drivers with features such as dynamic spectral light reproduction and advanced sensing capabilities.

Based on the Android application and designed bulb, Smart Bulb is being proposed in this paper. A simple method of controlling the surrounding light intensity and color according to various factors like temperature, humidity, mood, etc is presented. This RGB smart bulb provides a low-cost design which is flexible and easy to use as it can be used with android smart phones via Bluetooth module. Also, it can monitor the surrounding temperature and humidity. It can be used to get visual notification alert from application without making sound.

This Smart Bulb can also be used in the parties and at some functions to produce the color according to the music. The user can also set alarm and wake up at time without disturbing others. The android application is used for many applications for example to control various features like intensity and color of Smart bulb, display temperature and humidity data on smart phone, switches on and off the Smart bulb, gives notification alert by changing its color.

Conflict of Interest

The authors declare no conflict of interest.

REFERENCES

- [1] F. Nouvel et al., "Wireless music controlled leds: MUSIC COLORZ," 4th European Education and Research Conference (EDERC 2010), Nice, pp. 106-110, 2010.
- [2] X. Qu, S. C. Wong and C. K. Tse, "Temperature Measurement Technique for Stabilizing the Light Output of RGB LED Lamps," in IEEE Transactions on Instrumentation and Measurement, vol. 59, no. 3, pp. 661-670, March 2010.
- [3] S. Mahadeokar and M. Sardeshmukh, "Energy efficient PWM Dimmable Smart Digital LED driver," 2015 International Conference on Energy Systems and Applications, Pune, pp. 306-311, 2015.
- [4] Chun Wei Lin, Bing Shiun Hsieh and Ying Xu Tsai, "A dimming technique for light emitting diode," 2012 IEEE International Conference on Electron Devices and Solid State Circuit (EDSSC), Bangkok, pp. 1-3, 2012.
- [5] G. Curcio, L. Piccardi, F. Ferlazzo, A. M. Giannini, C. Burattini and F. Bisegna, "LED lighting effect on sleep, sleepiness, mood and vigor," 2016 IEEE 16th International Conference on Environment and Electrical Engineering (EEEIC), Florence, pp. 1-5, 2016.
- [6] C. M. de Melo and J. Gratch, "The effect of color on expression of joy and sadness in virtual humans," 2009 3rd International Conference on Affective Computing and Intelligent Interaction and Workshops, Amsterdam, pp. 1-7, 2009.
- [7] M. Perálvarez, et al. "Materials for sustainable energy applications: Conversion, storage, transmission and consumption", Ed. Pan Stanford Publishing ISBN 9789814411813, pp. 693-750, Barcelona, Spain, 2016.
- [8] M. Crawford. "LEDs for Solid-State Lighting: Performance Challenges and Recent Advances". IEEE J. Select Topics Quantum Electron., vol. 15, no. 4, pp. 1028-1040, Jul. 2009.
- [9] V. C. Bender, T. B. Marchesan and J. M. Alonso, "Solid-State Lighting: A Concise Review of the State of the Art on LED and OLED Modeling," IEEE Ind. Electron. Mag., vol. 9, no. 2, pp. 6-16, June. 2015.
- [10] A. De Almeida, B. Santos Bertoldi Paolo, and M. Quicheron. "Solid state lighting review – Potential and challenges in Europe." Renewable and Sustainable Energy Rev., vol. 34, pp. 30-48, June. 2014.
- [11] A. K. Jägerbrand. "New Framework of Sustainable Indicators for Outdoor LED (Light Emitting Diodes) Lighting and SSL (Solid State Lighting)". Sustainability, vol. 7, no. 1, pp. 1028-1063, July. 2015.
- [12] R. L. Lin, Y. C. Chang and C. C. Lee, "Optimal Design of LED Array for Single-Loop CCM Buck-Boost LED Driver," IEEE Trans. Ind. Appl, vol. 49, no. 2, pp. 761-768, Mar-Apr. 2013.
- [13] H. L. Cheng, et al., "High-power-factor dimmable LED driver with low-frequency pulse-width modulation," IET Power Electronics, vol. 9, no. 10, pp. 2139-2146, Aug. 2016.
- [14] www.energystar.gov/lighting.
- [15] J. Higuera, et al., "Smart Lighting System ISO/IEC/IEEE 21451 Compatible," IEEE Sensors J., vol. 15, no. 5, pp. 2595-2602, May. 2015.